



Rigging Services



Complete “Rigging Office” Capabilities

Unique CHART-UR-BARTM SPREADER
SYSTEMS

Specialized Gear for Low-Headroom Lifts

BTH Engineering / Intellectual Property

Extensive Rigging and Lifting Inventory

Most Experienced Consulting / Design Team
in the Industry

Solid and Recognized Customer Base

Unbiased Approach with Strong Industry
Reputation

Zero Loss Safety Record

Value Proposition In-Line with Clients & Market Direction



Business Model is based on a Fully Integrated "Rigging Office"

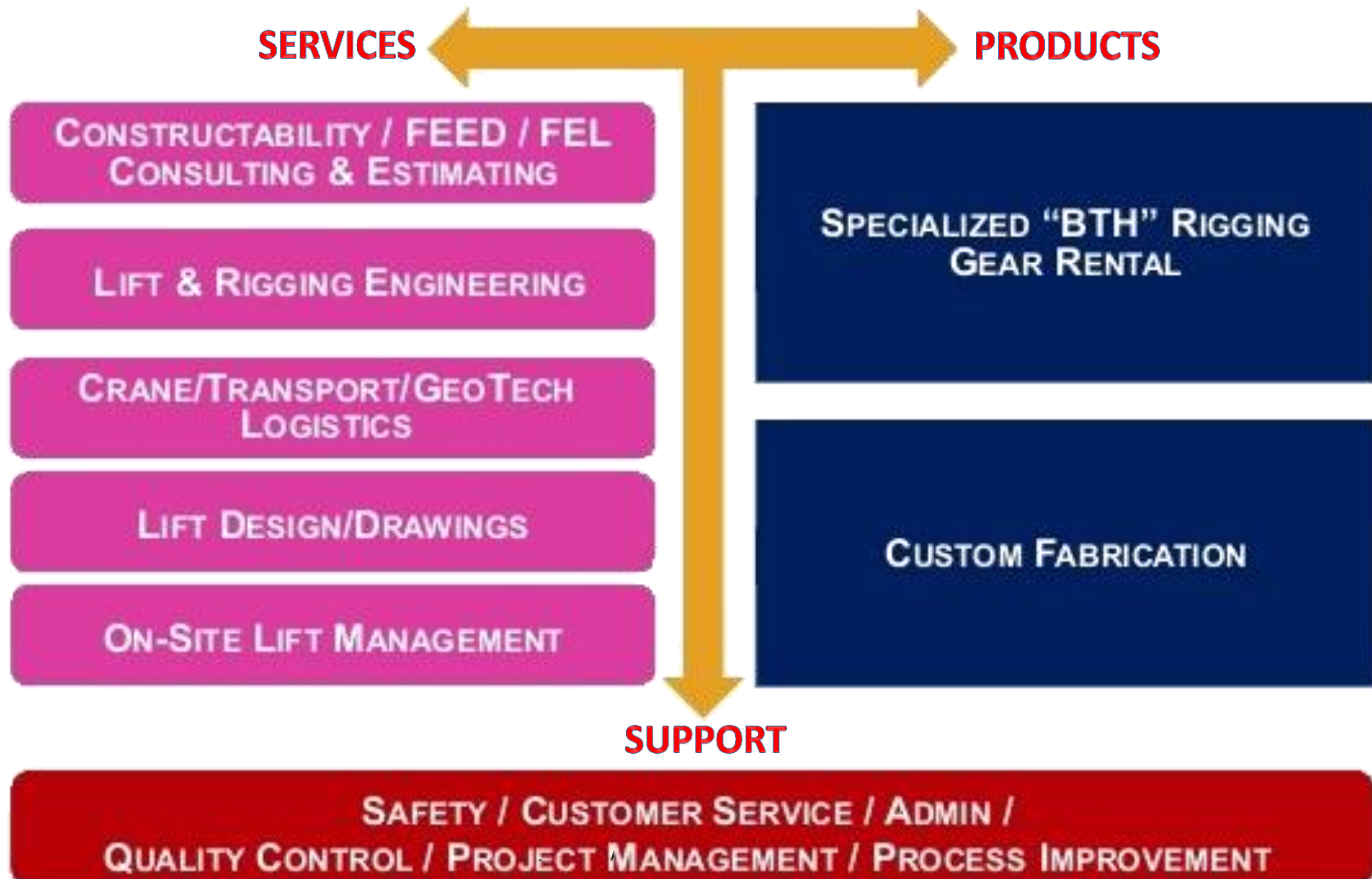



C Q Understands Customer Needs and Timeline

PROJECT PHASES	IDENTIFY	SELECT	DEVELOP	EXECUTE	OPERATE	
	<i>Identify & Access Opportunities</i>	<i>Generate & Select Alternatives</i>	<i>Develop Preferred Alternative</i>	<i>Manage Execution of Constructability Plans</i>	<i>Operate & Evaluate</i>	
	PHASE 1	PHASE 2	PHASE 3	PHASE 4	PHASE 5	
Rigging & Lifting Engineering Services	Feasibility / FEED / FEL Studies	✓				
	On-Site Assessment	✓				
	Risk Mitigation & Opportunity Analysis	✓				
	Constructability Consulting and/or Input		✓	✓	✓	
	Technical Bid Package & Lifting Equipment Budget Estimates	✓	✓	✓	✓	
	Lifting / Tailing Attachments / Lugs Design / Engineering		✓	✓	✓	
	Crane Selection Analysis to Suite Constructability Methods		✓	✓	✓	
	Transport Logistics		✓	✓	✓	
	Sub-Grade Data Analysis		✓	✓	✓	
	Preliminary & Final Engineering / Cost	✓	✓	✓	✓	
	Transport, Rigging & Lift Design & Drafting		✓	✓	✓	
	Custom Fabrication Identification & Cost		✓	✓	✓	✓
	BTH Rigging & Lifting Gear Identification, Specifications & Rental Cost			✓	✓	✓
	On-Site Transport, Rigging & Lifting Management				✓	✓
On-Going Process Improvement / Lessons Learned					✓	

"BTH" Lifting Gear is Uniquely Engineered, Safer and Configurable to Meet Multiple Needs



Pictures represent only a small sample of the specialized lifting devices ZH haYH engineered and manufactured

Importance of a Safe and Cost Efficient Rigging Solution

The increasing understanding of the benefits of a comprehensive BTH Solution!

**982 Tons
20 Point Lift**

“Design & Rigging between the Hook and the Load will have the greatest impact on heavy lift project safety and cost”

Comprehensive Rigging Rental Inventory

C Q Offer the following:

CHART-UR-BAR™ SPREADER SYSTEMS & TOOLS

- CHART-UR-BAR™ SPREADER BAR SYSTEMS
- CHART-UR-BAR™ SPREADER FRAMES SYSTEMS (30°&45°)
- OCTA-LIFTERS
- OCTA-SPREADERS
- HEXA-LIFTERS
- HEXA-SPRADERS
- TRI-SPREADER SYSTEMS
- Rolling Blocks (to 400+tons)
- LIFTING BEAMS
- PLATE BARS (6 TO 165 TONS CAPACITY)
- LIFTING ELBOWS



2 to 5 / 2 to 6 / 2 to 7 / 2 to 8



Featuring CHART-UR-BAR SYSTEMS & Specialized BTH Tools To Address Market Requirements (THIS PAGE IS INCOMPLETE-MANY TOOLS NOT LISTED)

CHART-UR-BAR VARIABLE SPREADER BARS SYSTEMS	CHART-UR-BAR VARIABLE SPREADER SYSTEMS	CHART-UR-BAR SPECIALTY DEVICES	CHART-UR-BAR PLATE BARS
18.7 TONS CUBSS	50 TONS 30d CUBSFS	120 TONS OCTA-LIFTER	20' Plate Bar (65-75 Tons)
55 TONS CUBSS	50 TONS 45d CUBSFS	330 TONS HEXA-LIFTER	19' Plate Bar (60 Tons)
77 TONS CUBSS	110 TONS 30d CUBSFS	440 TONS OCTA-LIFTER	15' Plate Bars (165 TONS)
121 TONS CUBSS	110 TONS 45d CUBSFS	660 TONS OCTA-LIFTER **	13' 6" Plate Bars (35 Tons)
165T LOW-HEADROOM CUBSS	220 TONS 45d CUBSFS	120 TON HEPTA-LIFTER	11' 4" Plate Bar (35 Tons)
165 TONS CUBSS	242/363 TONS 30d & 45d CUBSFS	220 TONS OCTA-LIFTER	6' 6" Plate Bars (35 Tons)
275 TONS CUBSS	660 TONS 30d & 45d CUBSFS	330 TONS HEXA-LIFTER	2' Plate Bar (5 Tons)
440 TONS CUBSS	1100 TONS OCTA-SPREADER	440 TONS OCTA-LIFTER	16' Plate Bars (165 Tons)
440 TONS 24" CUBSS-1	848 Tons TETRA-DECA SPREADER	660 TONS VARIABLE LUGS LIFTER	
440 TONS 24" CUBSS-2	110 TONS CUBSFS MIDSLEEVES	77 TONS MIDSLEEVES	
660 TONS CUBSS	660 TONS CUBSFS MIDSLEEVES	660 TONS MIDSLEEVES	
880 TONS CUBSS	495 TONS HEXA-SPREADER 220 TONS OCTA-SPREADER	121 TONS CUBSS MIDSLEEVES	
1100 TONS CUBSS	440 TONS OCTA-SPREADER 660 TONS OCTA-SPREADER	165 TONS CUBSS MIDSLEEVES	
1540 TONS CUBSS	99 TONS TRI-SPREADER 181.5 TONS TRI-SPREADER	242/363 TONS CUBSFS MIDSLEEVES	
1980 TONS CUBSS		275 TONS CUBSS MIDSLEEVES	
2200 TONS CUBSS			

Specialized Rental Inventory

Complete Line of Specialized Rigging & Lifting Devices & Tools

- WIRE ROPE SLINGS & GROMMETS
- SHACKLES up to 990 tons
- TRI-LINKS up to 660 tons
- LIFTING ELBOWS
- DUAL TURNBUCKLES
- MASTER LINKS UP TO 5"
- SPECIALIZED LINKS
- SPECIALIZED HOOK LINKS
- LIFTING LUGS/TRUUNIONS



Differentiated through its Experienced Design Team

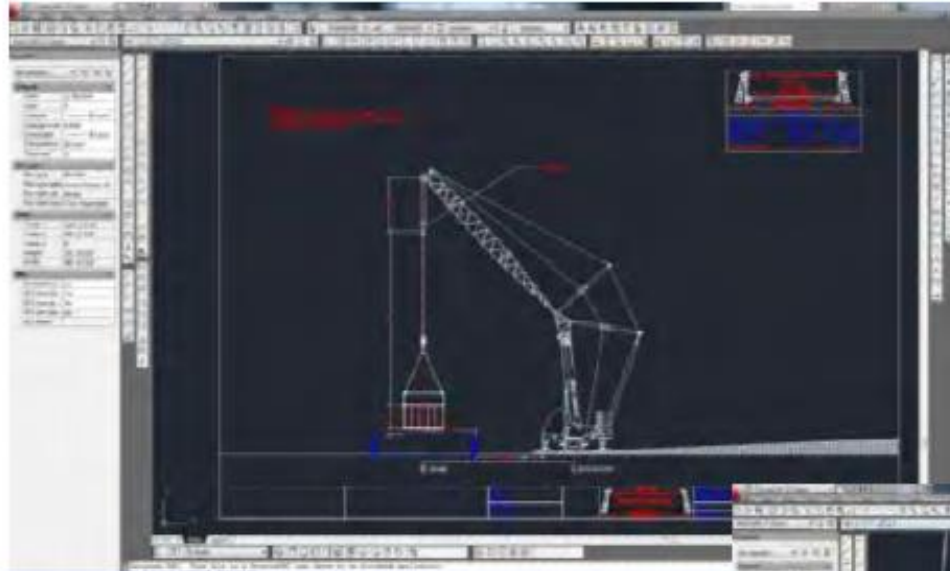

Computer Aided Design & Drafting

- Rigging Diagrams, Elevation Views, Site Dimensional Surveys Plans
- Design & Engineering of BTH Rigging
- 100% Compliant with ASME Codes
- ACAD, Inventor, Carol Programs

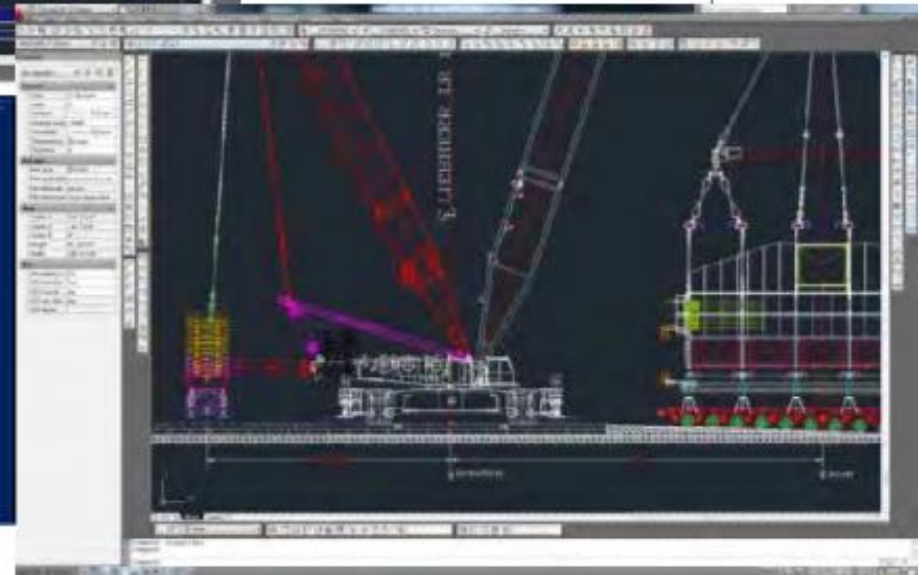

Another Differentiator is RXU Ability to Design, Engineer and Fabricate the Product

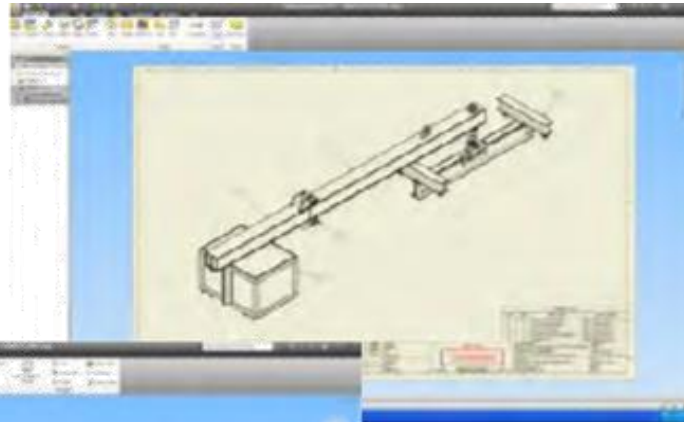

Notes:

- 1. With Bore length and ID
- 2. With Bore length and ID
- 3. With Bore length and ID
- 4. With Bore length and ID

Dimensions:

- 1. Bore length and ID
- 2. Bore length and ID

Dimension values in the table are the ID of the edge of the reference feature for the ITM in context. The ITM is the ID of the edge of the edge.

An assembly order table is included in the latest data link file.

$H_{max} = 1.0000$ Max Bore height
 $H_{min} = 0.9999$ Min Bore height
 $H_{max} = 1.0000$ Max Bore height
 $H_{min} = 0.9999$ Min Bore height
 $H_{max} = 1.0000$ Max Bore height
 $H_{min} = 0.9999$ Min Bore height
 $H_{max} = 1.0000$ Max Bore height
 $H_{min} = 0.9999$ Min Bore height
 $H_{max} = 1.0000$ Max Bore height
 $H_{min} = 0.9999$ Min Bore height
 $H_{max} = 1.0000$ Max Bore height
 $H_{min} = 0.9999$ Min Bore height

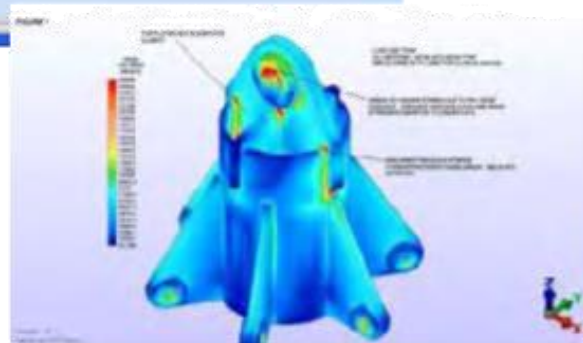

Engineering Support Tools:

- Inventor 3D Modeling
- Finite Element Analysis (FEA)
- Ground Bearing Pressure Calculations, & much more
- Software: Inventor, MathCAD, ALGOR Simulation

CRANES SPECIFICATIONS & EVALUATION ANALYSIS MATRIX

Evaluation Matrix: Highlights Various Lift Options/Best Fit

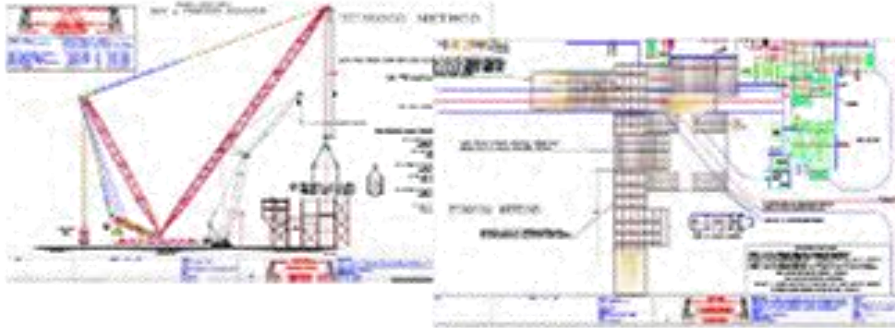
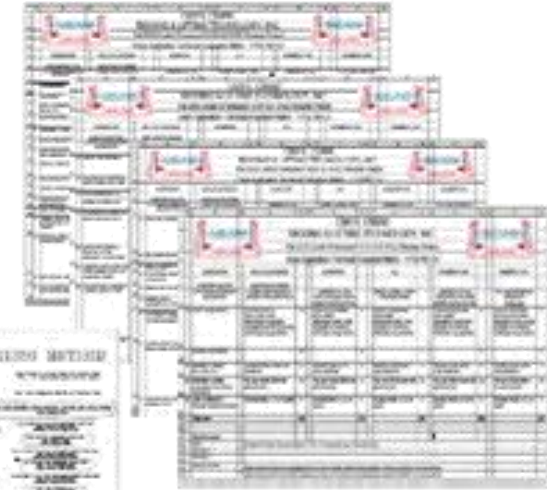
Evaluation Matrix table showing various lift options and their best fit. The table has multiple columns and rows, with red highlights indicating the best fit for each option.

Option	Option 1	Option 2	Option 3	Option 4	Option 5	Option 6	Option 7	Option 8	Option 9	Option 10	Option 11	Option 12	Option 13	Option 14	Option 15
Option 1
Option 2
Option 3
Option 4
Option 5
Option 6
Option 7
Option 8
Option 9
Option 10
Option 11
Option 12
Option 13
Option 14
Option 15

We Spec the Crane - Custom Design and Engineering Evaluation Process

- Lift Constructability
- Crane Sizing and Selection
- Crane Positioning
- Geo-Tech Soil and Sub-Grade analysis
- Crane Foundation Design
- Project Assessment through SEVEN (7 to 15) elements of the lift
- Critical Route Analysis and Logistics
- Explore and Determine Crane Requirements & Availability
- Cost Projections, Estimates & Alternatives
- Job Safety – Hazard Analysis (See CCRLT, INC. CODE SYSTEM)



Crane(s) Analysis Specifications & Requirements Evaluations

- Transport, Crane & Rigging Selection -Technical Evaluation & Recommendations
- Identifying & Considering all Positive & Negative Impacts
- Experienced in Project Exposure Identification & Establishing Mitigation Methods

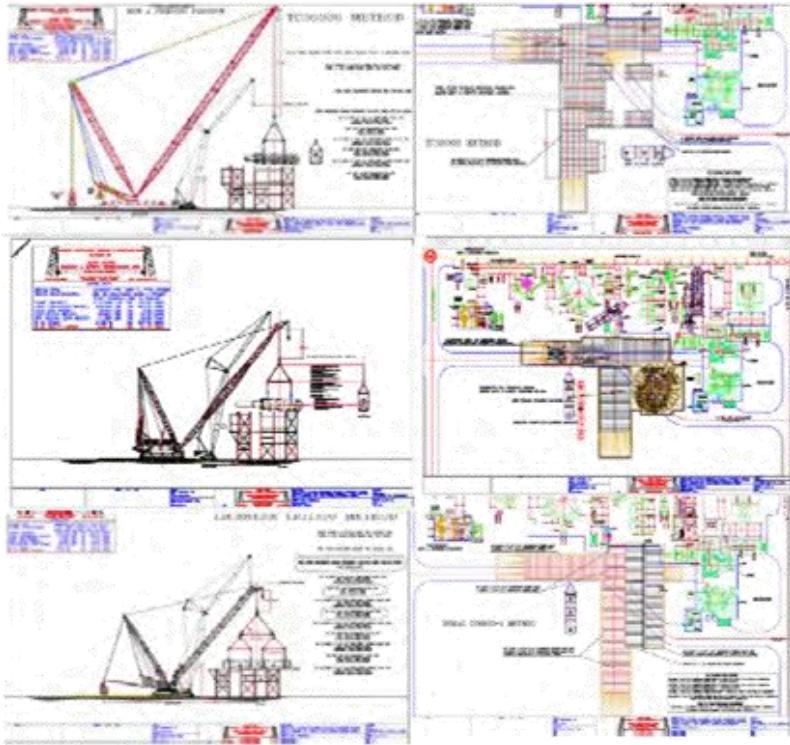
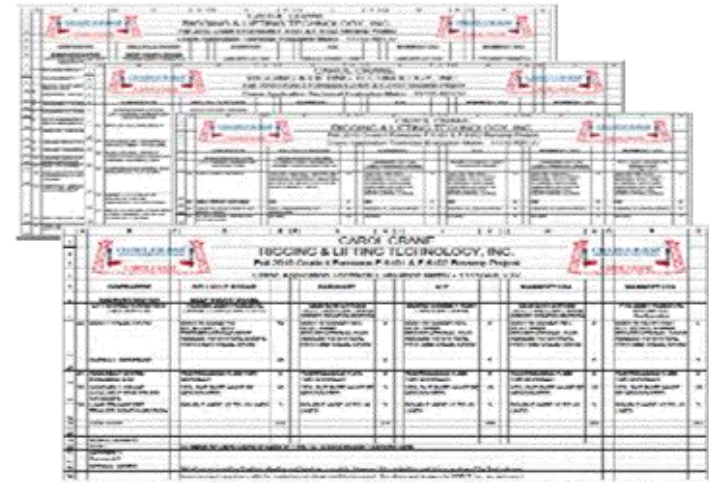
Crane, Rigging & Transporter Evaluation Matrix Designed & Tailored to Address Plant & Project's Conditions & Challenges With the Applicable Cranes, Rigging and Lifting Options Offered & Available in the Market

Utilizing our **CODE** Process for Owner Success

Some of the areas considered & reviewed could include: Geotechnical Conditions, i.e. Soils Report, Allowable Bearing Existing Underground Facilities, Crane Reactions, Sub Grade Engineering

- Constructability Optimization Thru Experienced Front End Loading Methods
- Impact to Other Facility Units
- Lifting Devices Design, Location & Elevation
- In Plant Critical Route Analysis
- Equipment Availability in the Market
- Critical Clearances and Capacities
- Exposure Identification & Mitigation Methods, Etc. Etc.

CONSTRUCTABILITY
OPTIMIZATION
DEVELOPMENT for
EXECUTION

UTILIZING OUR CHART-UR-BAR SPREADER SYSTEMS AND OUR OTHER SPECIALIZED BTH TOOLS INVENTIONS WHEN APPLICABLE TO PROJECT SAFETY & SCHEDULE ENHANCEMENT PROVIDING EXPERIENCED ON SITE MANAGEMENT BY OUR TRANSPORT RIGGING & LIFTING SPECIALISTS CAROL RIGGING & LIFTING ENGINEERING PRIORITY IS THE PROTECTION OF LIVES LIMBS & PROPERTY

RIGGING & LIFTING GEAR RENTAL

Complete Line of BTH Rigging Gear and Specialized Lifting Devices and Tools

- Key Hole Bales
- Lifting Bales
- Trunnions with Bales
- Chain falls
- Flanged Lifting Devices
- Staging Stands
- Stack Stabilizer Rings
- Exchanger Extractors / Lifter
- Tailing Beam Assemblies
- Certified Personal Baskets
- Material Baskets
- Steel Crane Mats (Various Sizes)
- Personnel / Material / Rigging Storage
- Steel Mats / Skid Pans
- Jack Stands



CUSTOM FABRICA

Specialized Beams . Specialized Spreader Bars . Lifting Beams Counter Balance Beam . Rolling Blocks . Variable Rigging Link Plates . Personnel Baskets . Material Baskets



Quality Assurance

- *Certified Welders and Fabricators*
- *Weld Inspection Reports*
- *Quality Control*
- *ASME BTH-1 2011 Compliant*

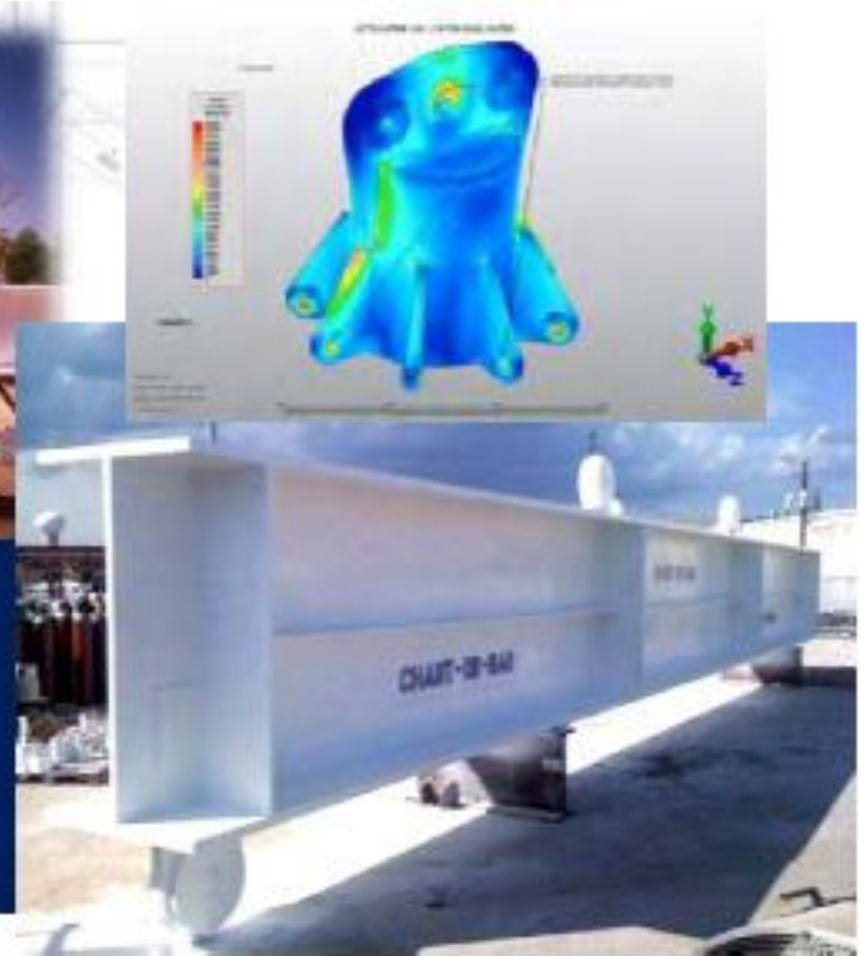

LIFTING AND TAILING DEVICE DESIGN

Lift Devices

- Lifting lugs
- Trunnions
- Top Nozzle Attachments

Tailing Devices

- Tailing lugs
- Tailing Beams
- Tailing Trunnion

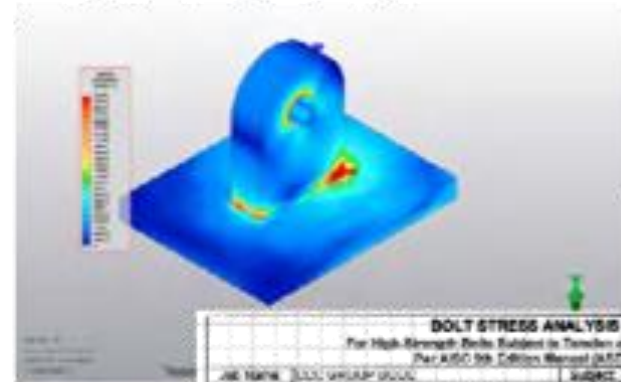

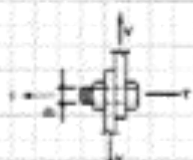
BOLT STRESS ANALYSIS		
For High-Strength Bolts Subjected to Tension and/or Shear		
Per ASCE 88 Edition Manual (ASCE)		
Job Name	DATE GROUP/SCALE	SUBJECT: LUGS DESIGN/COMP. PARTITION
Job Number		Organization / User
LOAD DATA		
Tension Force/No. of T	3.70	kip(s)
Clearance/No. of V	4.85	kip(s)
Bolt Diameter, d	0.750	in
ASCE Manual Group	A325	
Full Tension (N, or RC)	N	
Bolt Hole Type	Standard	
Single or Double Shear	Single	
No. of Loading Cycles	10	(or 20 years)
DETAILS		
		
SUBROUTINES		
** refer to VTs from ASCE Table 23.7 for A325 bolts		

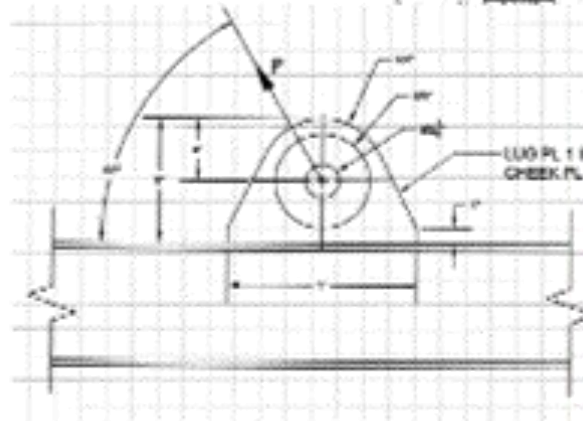
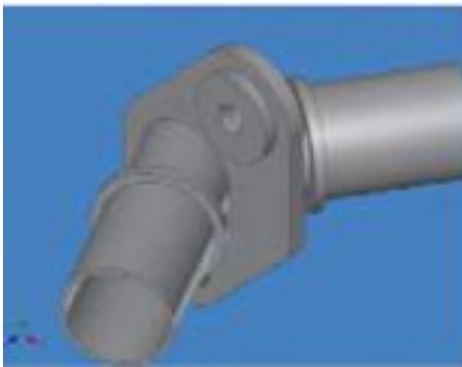

TRANSPORT LOGISTICS

- Transport Engineering & Logistics
- Technical Logistics
- Transport Plans
- Design Plans
- Hazard Analysis and Assessment
- On-site management
- ACAD Site-Plan design for inside the Plant Transport
- Specialized Trailer Configuration drawings
- Turning Radius drawings
- Storage Plans for Rigging and Lifting Gear
- Lashing Calculations and diagrams
- Transportation Consulting for outside the plant transport
- Barge Ballast Calculations



Project Manager – Job Summary

- Creates and executes project work plans
- Revises project plans to meet changing needs and requirements
- Identifies needed resources
- Assigns Responsibilities
- Manages day-to-day operational aspects of project Maintains relational scope of the project
- Reviews Deliverables – Provides to Client
- Applies standard methodology – See the CODE Enforces Project Standards
- Coordinates Project Reviews
- Maintains Quality Assurance Procedures
- Ensures minimum Exposure and Risk
- Ensures Project Documents are complete, current and properly secured



CUSTOMIZED CRANE LOAD TESTING

Custom rigging and design solutions provided to meet challenging load test applications and specific requirements.

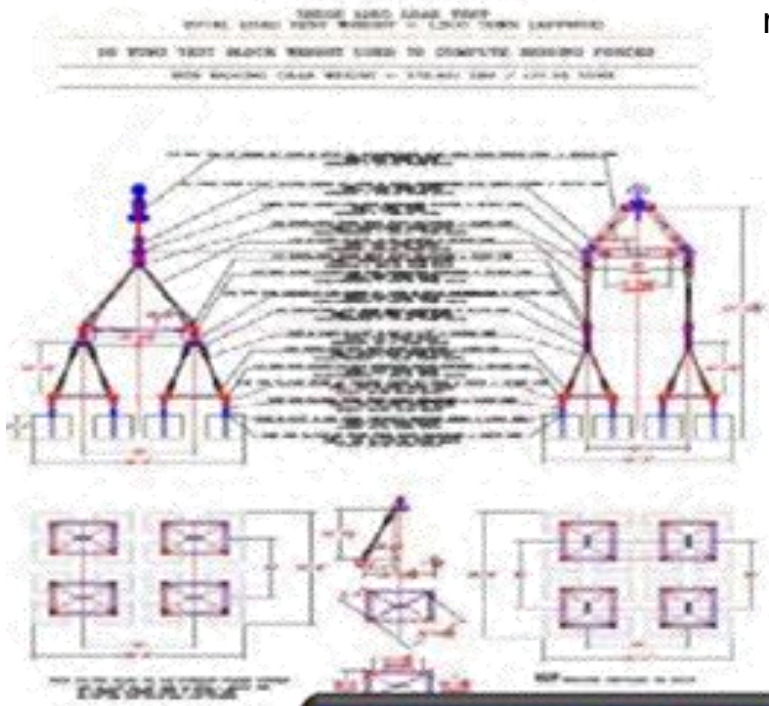

SLING TEST/CERTIFICATIONS MANAGEMENT

CHAOTIC & CONFUSING

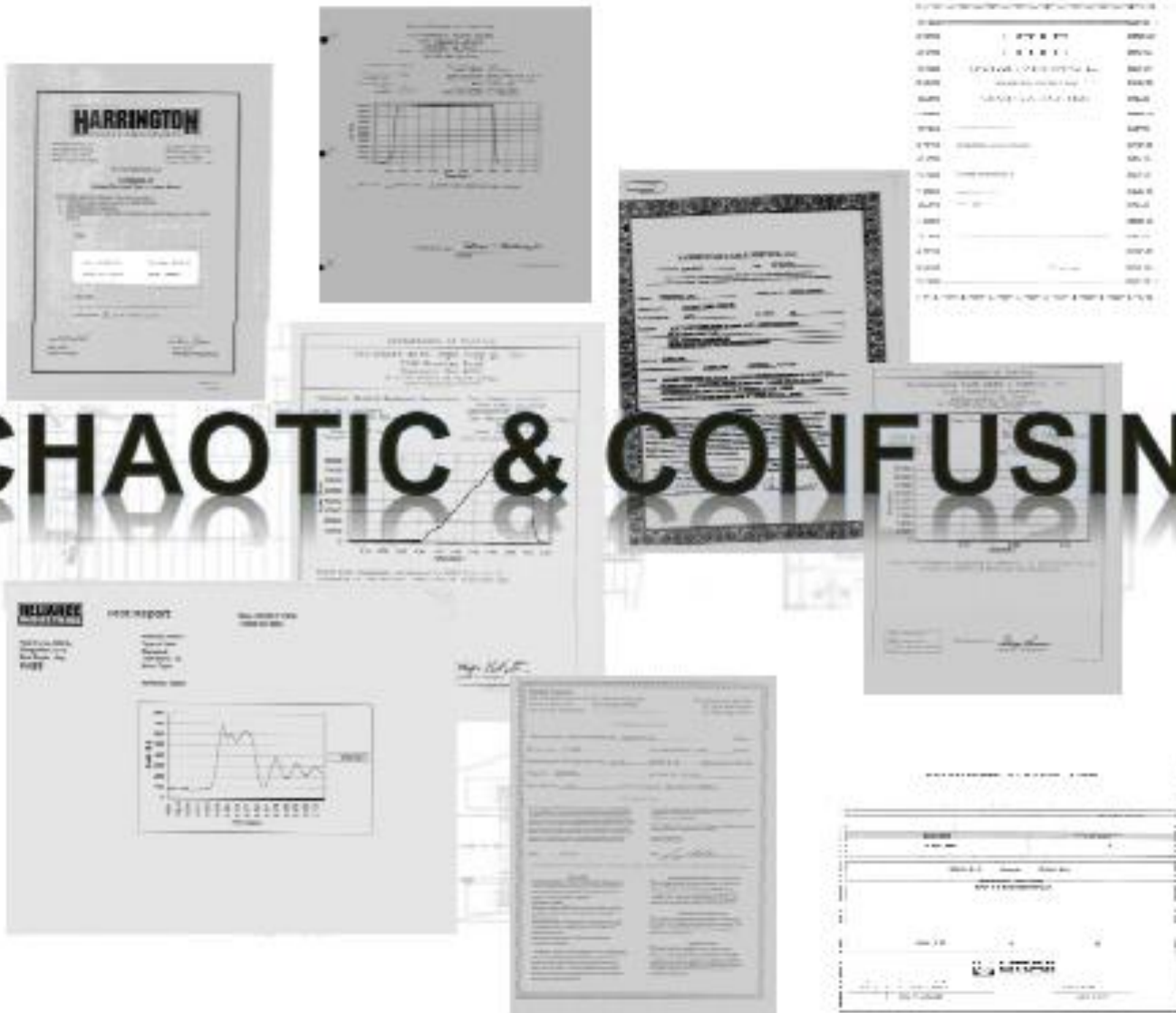



CHART-UR-BAR SPREADER SYSTEMS Provide a Simple Way for Clients to Configure Spreader Systems

 CHART-UR-BARSM SPREADER BAR SYSTEMS CAROL CRANE HOODING & LIFTING TECHNOLOGY, INC. 2829 Pasadena Blvd., Pasadena, Texas 77028 713-475-7181 Office or 713-475-7171 Fax							
440 TON CAPACITY CURSES CHART							
CAPACITIES ARE IN SHORT TONS							
SPREADER BAR SPAN (ft. - in.)	SLING ANGLE 45°		SLING ANGLE 60°		TOTAL WEIGHT (lbs)		INSERT LENGTH (ft. - in.)
	SC1 40	SC1 80	SC1 40	SC1 80	SC1 40	SC1 80	
59	160.8	228.9	245.8	345	15006	16476	54' 6"
60	156.7	228.6	239.3	379.3	13927	18827	55' 6"
61	128.7	208.2	223	398.1	12090	18390	56' 6"
62	123	207.2	219.2	391.8	14178	18906	57' 6"
63	117.5	207.9	205.5	329.3	11298	18111	58' 6"
64	117.1	179	192.1	310	14619	19517	59' 6"
65	106.9	170.5	185.1	295	12567	18751	60' 6"
66	101.8	187	176.4	290.5	14689	19829	61' 6"
67	97	155.9	161	268.6	14758	20129	62' 6"
68	92.3	146.1	159.8	253.1	14920	20329	63' 6"
69	87.7	136.6	152	240.1	15033	20567	64' 6"
70	83.3	131.4	144.4	227.6	15156	20776	65' 6"
71	78.1	124.4	137.1	215.5	15278	20966	66' 6"
72	75	117.7	130	203.9	15402	21193	67' 6"
73	71.1	111.7	123.2	192.6	15525	21401	68' 6"
74	67.3	105	116.6	181.0	15648	21611	69' 6"
75	63.6	98.9	110.2	171.4	15771	21820	70' 6"
76	60.1	93.1	104.1	161.4	15894	22029	71' 6"
77	56.7	87.6	98.2	151.7	16017	22238	72' 6"
78	53.4	82.3	92.5	142.5	16139	22447	73' 6"
79	50.3	77.2	87.1	133.0	16262	22656	74' 6"
80	47.5	72.1	81.9	123.3	16385	22865	75' 6"
81	44.8	67.2	77	113.3	16508	23074	76' 6"
82	42.7	62.9	72.4	104.9	16631	23283	77' 6"

Empowers field resources to determine bar capacities, insert lengths, pipe requirements, etc.

NOTE:  — INDICATES LIMIT BY SHACKLE CAPACITY — TOP SHACKLE 300 t Wt, BOTTOM SHACKLE 200 t Wt.

THIS SYSTEM WEIGH AND OR EXCEEDS THE FOLLOWING SPECIFICALLY DESIGNATED FOR ADAPT WITH 1 1/2" DIA. ALL WEIGHTS PER BAR SCALE. NOTE: SUBJECT TO CHANGE WITHOUT NOTICE - SHOW TO WEIGHT UNIT & CO.

Copyright © 2007 Carol Crane Hooping & Lifting Technology, Inc. Houston, TX 77028. All rights reserved. 713-475-7181 Office or 713-475-7171 Fax.

CONFIDENTIAL — DO NOT REPRODUCE OR DISTRIBUTE WITHOUT WRITTEN APPROVAL FROM CAROL CRANE OWNER.

Inventory management system combines the right asset with the right design

- Proprietary inventory management tools: “SERVICE Program”
 - Built to address both inventory management and lift design requirements of our Clients

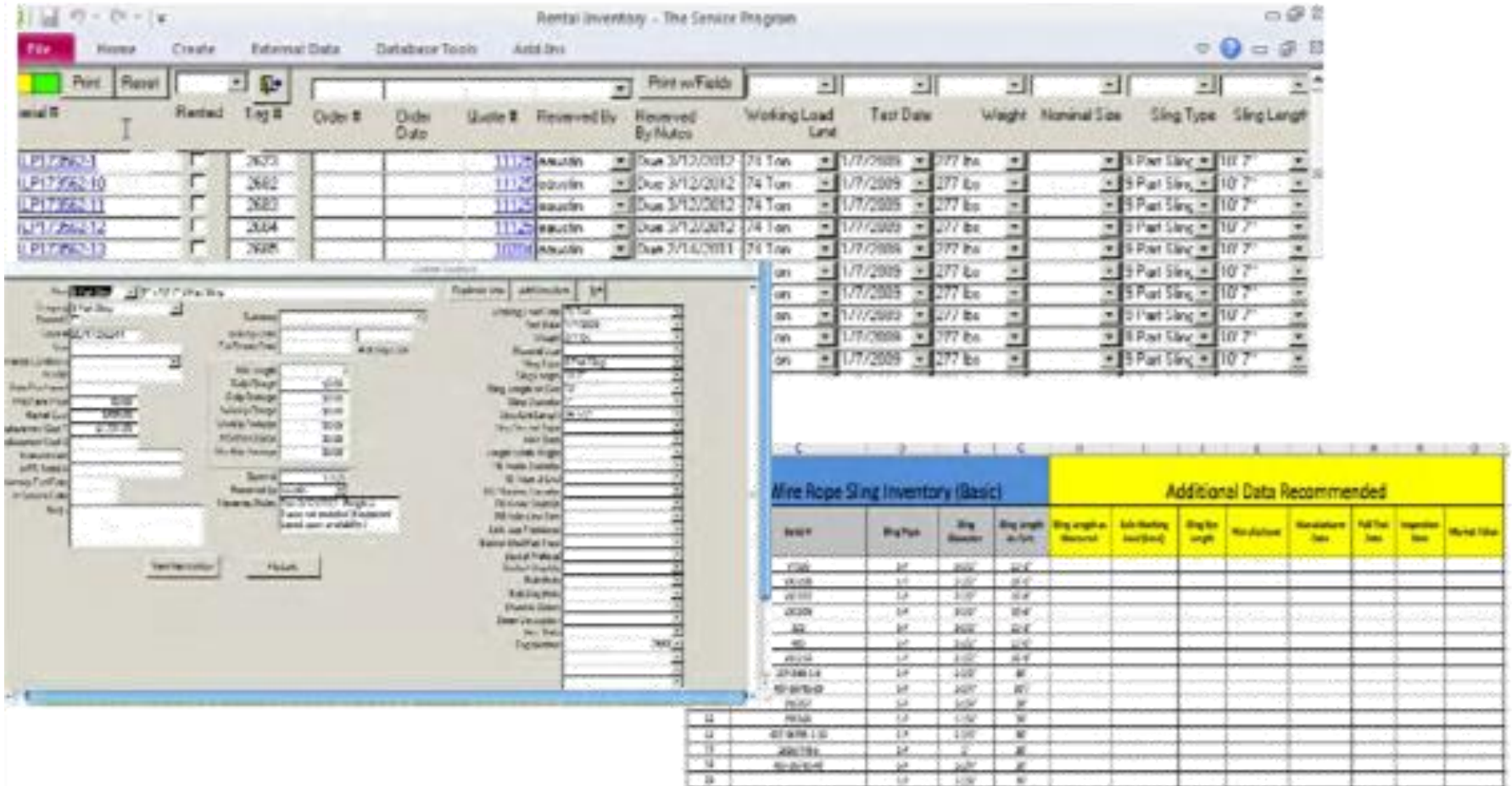

The screenshot displays the 'SERVICE Program' interface for 'Rental Inventory'. The main window shows a list of inventory items with columns for Item #, Rented, Tag #, Order #, Order Date, Quote #, Received By, Received By/Notes, Working Load Limit, Test Date, Weight, Nominal Size, Sling Type, and Sling Length. Below this, there is a detailed view of a 'Wire Rope Sling Inventory (Basic)' table with columns for Item #, Sling Type, Sling Diameter, Sling Length in Feet, Sling Weight in Pounds, End Hooking (inches), Sling Test Weight, Nominal Size, Full Test Date, Inspection Date, and Market Value.

Item #	Sling Type	Sling Diameter	Sling Length in Feet	Sling Weight in Pounds	End Hooking (inches)	Sling Test Weight	Nominal Size	Full Test Date	Inspection Date	Market Value
1700	3/4"	3/4"	10'	10'						
1701	1/2"	1/2"	10'	10'						
1702	3/4"	3/4"	10'	10'						
1703	1/2"	1/2"	10'	10'						
1704	3/4"	3/4"	10'	10'						
1705	1/2"	1/2"	10'	10'						
1706	3/4"	3/4"	10'	10'						
1707	1/2"	1/2"	10'	10'						
1708	3/4"	3/4"	10'	10'						
1709	1/2"	1/2"	10'	10'						
1710	3/4"	3/4"	10'	10'						
1711	1/2"	1/2"	10'	10'						
1712	3/4"	3/4"	10'	10'						
1713	1/2"	1/2"	10'	10'						
1714	3/4"	3/4"	10'	10'						
1715	1/2"	1/2"	10'	10'						
1716	3/4"	3/4"	10'	10'						
1717	1/2"	1/2"	10'	10'						
1718	3/4"	3/4"	10'	10'						
1719	1/2"	1/2"	10'	10'						
1720	3/4"	3/4"	10'	10'						



BEST PRACTICES/LESSONS LEARNED

- ❑ Critical to Engage Early
 - Project evaluation stage (1)
 - Lack of Experience will be magnified in execution if not addressed early
- ❑ Areas to address with most Significant Impact
 - Lift Strategy & Design (with focus on construability improvement)
 - Transport Approach
 - Sub-Grade Requirements
 - Crane Selection
 - Crane Positioning
 - Specialized Rigging Gear
- ❑ Rigging & Lifting Team must focus on the Total Project Success and not just the R&L Requirements
- ❑ The Area most often over estimated in Capital and/or Turnaround Projects is Projected Days to Complete Project (by using our processes and experienced team clients will reduce downtime)
 - ✓ The Impact of only a few days can mean millions in both direct and lost production cost!
- ❑ The Rigging and Lifting decisions will ultimately have the most positive or negative impact on the project



2XU Growth Model Fits Emerging Industry Drivers

COST SAVING AND SHORTEN SCHEDULES ARE DRIVING MODULAR CONSTRUCTION

..... WHICH GUARANTEES THE NEED FOR EXPERIENCED RIGGING & LIFTING TOOLS, STAFF AND SERVICES

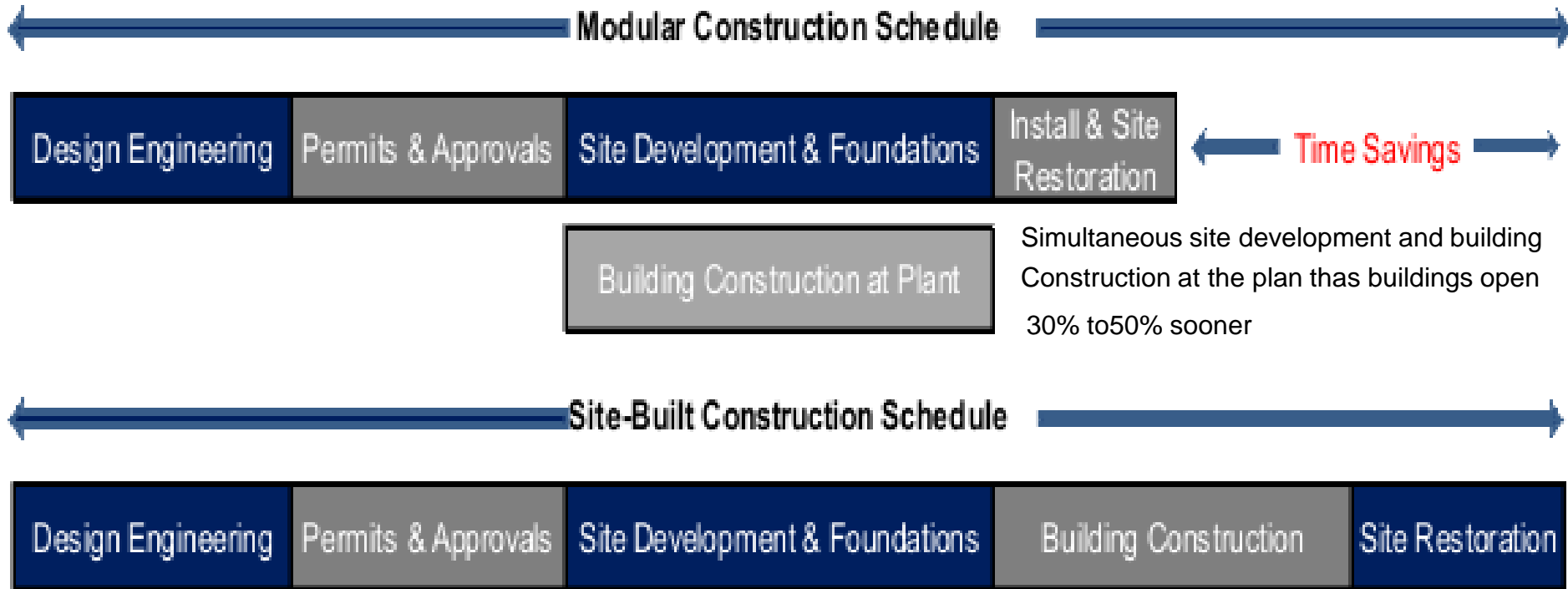

“Permanent modular construction is an evolution from prefabrication that has been enabled greatly by the integration of three and four-dimensional building design software.”

Questions

Contacts Us



Phone:
+1 832 800-0266



Web Site:
<http://www.houstonusaoiltech.com/>



LinkedIn:
[linkedin.com/company/houston-usa-oil-technologies](https://www.linkedin.com/company/houston-usa-oil-technologies)



Facebook (Fan Page):
<https://www.facebook.com/h.usaoiltech>



Email:
info@houstonusaoiltech.com



Twitter:
https://twitter.com/h_usaoiltech



Messenger:
m.me/h.usaoiltech



Instagram:
[@h_usaoiltech](https://www.instagram.com/h_usaoiltech)



We Greatly Appreciate Your Time!